

KM-1301SAH



WaterMark
ATS 5200.105
22349, 22350, 22351



WaterMark
ATS 5200.105
22349, 22350, 22351



KM-1301SAH + B-801SA

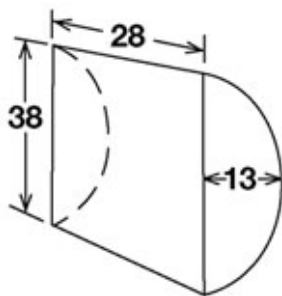

Product Specifications

COOLING	Air
WEIGHT	Net: 120kg Packed: 143kg
AC SUPPLY VOLTAGE	220 - 240V / 50Hz 15Amps
REFRIGERANT	R404A
AMBIENT	1 - 40°C
WATER TEMP	5 - 35°C
WATER PRESSURE	50 - 800kPa
ICE PRODUCTION PER 24 HOURS (APPROX)	Air temp: 10°C Water Temp: 10°C - 584kg Air temp: 21°C Water Temp: 15°C - 522kg Air temp: 32°C Water Temp: 21°C - 465kg
ICE PRODUCTION PER CYCLE	13.2kg / 1440pcs
FREEZE CYCLE	35mins
MAX STORAGE CAPACITY	Select Bin

Product Range

PART NO.	DESCRIPTION	LIST PRICE
91000018	KM-1301SAH	\$13532.40
91000051	KM-1301SWH	\$12120.15

KM-1301SAH

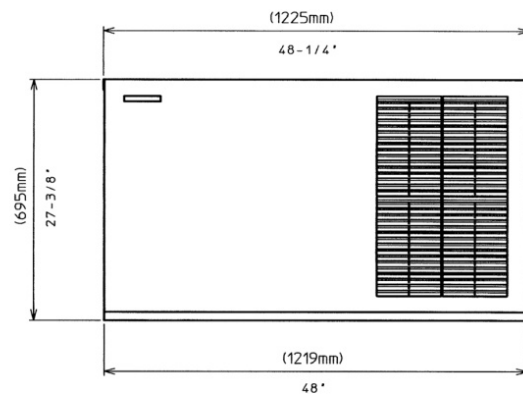
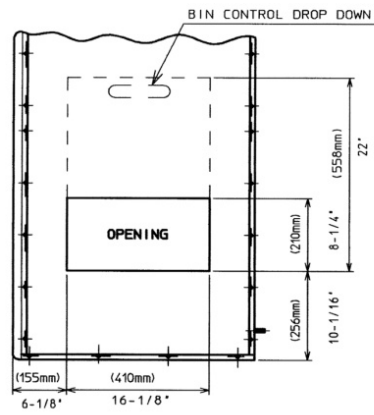
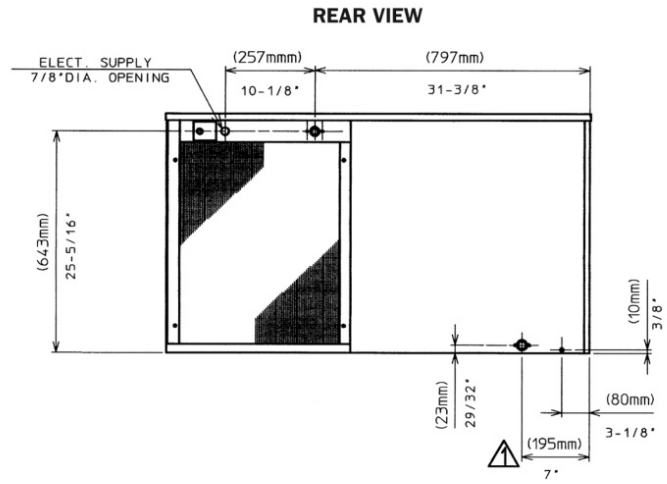
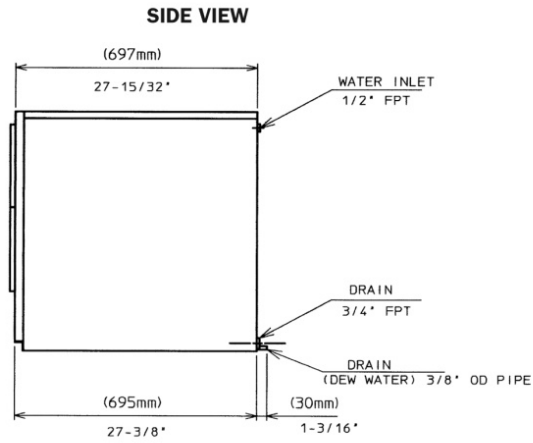

BOTTOM VIEW

FRONT VIEW